

Panasonic®

AW-SW350

Live Switcher

5-input, Compact Size Live Switcher



A high quality 5-input live switcher for multi use

Panasonic introduces a 5-input live switcher with wipe, mix, key, and fade functions. This switcher works with external DC power for remote field production. Its small size makes it convenient to carry.

KEY FEATURES

5-input live switcher

AW-SW350 has a built-in, 10bit 5-channel frame synchronizer, which is useful for high-quality switching. This switcher can also has the Frame Synchronizer turned off and thus be used as a gen-lockable device.

Versatile functions

Three ways wipe (normal/reverse, normal, reverse)
 Nine wipe patterns
 Manual/Auto wipe(hard/soft) or mix (adjustable wipe or mix transition time)
 White/black/6 Colors background

DC operated compact switcher

This half rack size switcher can be operated by DC battery input so that it may be operated as a field switcher.

USB port available

USB port is available for mixing/keying video and characters or graphics from PC.

NTSC/PAL switchable

Compact live switcher AW-SW350 can be used in both NTSC and PAL format.

SPECIFICATIONS

Input signal	Composite video	VBS 1.0Vp-p/75ohmX5 (auto term.)	Function	Intercom	1~5 (6 pin connector, 3/4 wires switchable) Main frame (M6 jack)	
	Y/C	Y:1.0Vp-p C:0.286Vp-pX5 (S connector)		Tally control	1~5 open collector output	
	USB	USB 1.1		Color bar	SMPTE (NTSC), EBU (PAL)	
Output signal	Composite Loop through	Loop through output of composite Video output X each 1 (BNC)	External VR	External VR	Auto Take/Key Auto Time Adjustment, Incom. Level Adjustment, Key Level/ Key Clip Adjustment	
	PGM output	75ohmX3 (VBS:BNCX2,S: SX1)		External Switch	External Switch	WIPE,MIX,INPUT SELECTOR (1~5), Wipe Pattern Selector, Bar/Color/Black Selector, Input 5/Frame memory selection switch, Auto Take, Wipe Direction Switch
	PVW output	VBS 1.0Vp-pX1			Power	DC12V 1.35A (16W)*
	BBS output	BBSX1 (BNC), GL In/BBSoutX1			Ope. temperature	0°C~+40°C
Function	Wipe	Direction(normal/reverse, normal, reverse) Nine Patterns	Weight	4.9 lbs (2.2kg)		
	Background	White/Black/6 Colors	Dimension	8-1/4"(W) X 3-7/16"(H) X 6-15/16"(D) 210(W) X 86(H) X 177(D)mm		
	Key	GAIN, CLIP				
	Wipe/Mix	Manual (Fader lever)/auto (auto take)				

*Recommended Power Supply: AW-PS505(Power Supply)
 AW-CA9T1(Power Cable)

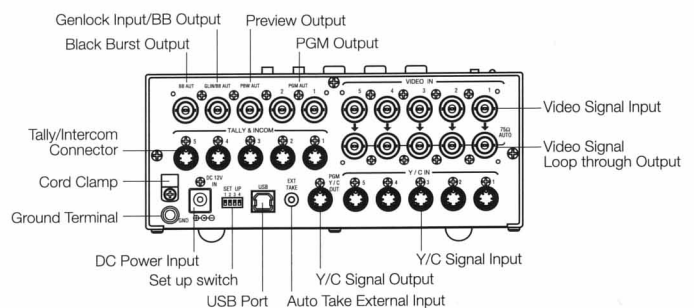
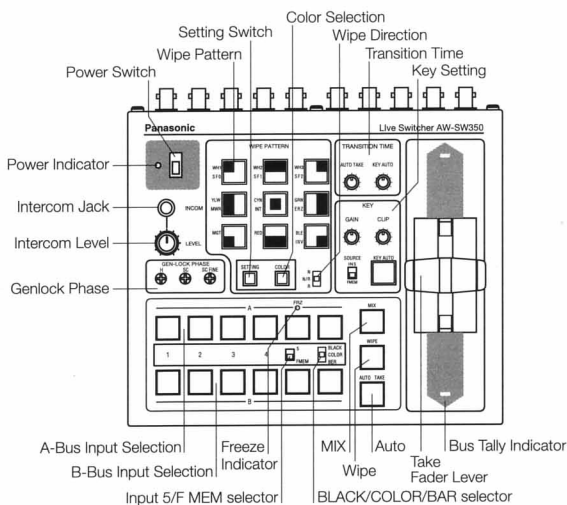

Panasonic

PANASONIC BROADCAST & TELEVISION SYSTEMS COMPANY
 DIVISION OF MATSUSHITA ELECTRIC CORPORATION OF AMERICA
www.panasonic.com/broadcast

Executive Office: One Panasonic Way 4E-7, Secaucus, NJ 07094 (201) 348-5300
EASTERN ZONE: One Panasonic Way 4E-7, Secaucus, NJ 07094 (201)348-7196
Central Region: 1707 N Randall Road E1-C-1, Elgin, IL 60123 (847) 468-5200
WESTERN ZONE: 3330 Cahuenga Blvd W., Los Angeles, CA 90068 (323) 436-3608
Government Marketing Department:
 52 West Gude Drive, Rockville, MD 20850 (301) 738-3840

Printed in Japan